

2009 Fall Technical Meeting
Organized by the Eastern States Section of the Combustion Institute
and Hosted by the University of Maryland College Park
October 18-21, 2009

An Examination of Cross Correlation Velocimetry's Ability to Predict Characteristic Turbulent Length Scales in Fire Induced Flow

S. Rockwell,¹ A. Rangwala,¹ and A. Klein²

*¹Department of Fire Protection Engineering, Worcester Polytechnic Institute,
Worcester, Massachusetts 01609, USA*

*²Department of Electrical and Computer Engineering, Worcester Polytechnic Institute
Worcester, Massachusetts 01609, USA*

Since the early 1970's Cross Correlation Velocimetry (CCV) has been used to measure velocity of turbulent flows. This study explores the use of the cross correlation coefficient decay towards estimation of characteristic turbulent length scales typically found in a fire. To test the theory, experiments were performed in a turbulent free jet and a natural gas fire plume. The experiments showed that CCV measurements were comparable to the velocity decay obtained using Laser Doppler Anemometer (LDA). Ultimately, a prototype probe was developed that could measure temperature, velocity, and flow width simultaneously in the plume of a natural gas burner. This allows for a direct estimation of the mass flow in a fire plume.

1. Introduction

Quantitative flow measurements in fires are difficult due to the extreme temperatures and density variations in both amplitude and frequency occurring in fire flows [1]. Normally a fire flow's width is determined by making multiple measurements along the width of either velocity or temperature, and estimating where the measured parameter decays to a minimal value. This study discusses the creation of a probe using Cross Correlation Velocimetry (CCV), known as a triple CCV probe, capable of simultaneously measuring the temperature, velocity, and flow width from a single measurement. The dependence of the probe on sampling frequency and sampling time are presented. This probe can be used to estimate a fire's plume width and possibly the ceiling jet thickness caused by a compartment fire. Measurement of fire plume temperature, velocity, and width also allows for the direct calculation of the fire's mass flux into the upper hot layer in a compartment fire. Characterization of ceiling jet thickness is important in the analysis of sprinkler activation, flashover calculations, and tenability/egress analysis in compartment fires that occur in, for example, structural and tunnel fires.

2. Operating Principle and Theoretical Background:

CCV uses temperature-time records from a set of thermocouples, one downstream of the other, cross-correlated to determine the flow's velocity similar to spatial and drift cross-

correlation velocimetry [2, 3]. The CCV technique uses the inherent turbulent structures generated by fire flows as the tracers to follow the bulk flow. CCV is based on the “frozen eddy” concept in turbulent flows proposed by Taylor in 1938 [4]. Taylor hypothesized that in a turbulent flow, there are random and unique eddy structures that retain their shape and characteristics over some small time and space. This concept is analogous to performing a numerical integration of a function over a small interval. In between 1975 and 1980 Cox et al. [5, 6] performed a series of experiments that verified the “frozen eddy” hypothesis in a non-isotropic ceiling-jet flow showing velocity measurements could be achieved by means of CCV and thus developing the one dimensional CCV probe. The velocity u of a flow can be calculated using [7],

$$u = \frac{d}{\tau}, \quad (1)$$

where d is the thermocouple separation distance in the direction of the flow and τ is the time lag (s) between the two thermocouple signals. Figure 1 shows an example of a turbulent jet with a dual CCV probe and sample temperature profile outputs.

Experimental measurements include signal noise and dissipation of small eddy structures which make the measurement of τ more difficult. To measure τ in a signal with noise, in which a visual measurement is not possible, the time lag τ can be calculated using,

$$\tau = \frac{\tau_{sN}}{f}, \quad (2)$$

where τ_{sN} is the nominal sampling lag, or the number of data samples the second signal is delayed behind the first, and f is the sampling frequency. τ_{sN} is found by calculating at what lag the non-dimensional cross coefficient ρ_{xy} has a maximum as shown in figure 2. To make the thermocouple data easier to manage numerically, the temperature profiles are normalized using,

$$\theta = \frac{T_s - T_{avg}}{T_{max}}, \quad (3)$$

where T_s is the measured temperature, T_{avg} is the mean temperature of the data set, and T_{max} is the maximum temperature in the data set. The nondimensionalized cross correlation coefficient ρ_{xy} can be calculated using,

$$\rho_{xy} = \frac{\lim_{T \rightarrow \infty} \frac{1}{T} \int_0^T \theta_x(z - \tau_s) \theta_y(z) dt}{\left[\theta_x(z - \tau_s)^2 \right]^{0.5} \left[\theta_y(z)^2 \right]^{0.5}}, \quad (4)$$

where z is the position in the temperature profile, τ_s is the sampling lag, T is the total number of samples, and $\theta_x(z)$ and $\theta_y(z)$ represent the normalized first and second temperature readings respectively. By plotting ρ_{xy} verses τ_s the nominal sampling lag τ_{sN} is found as the abscissa of the peak. Figure 2 shows an example of ρ_{xy} verses τ_s plot using a f of 2 kHz and a d of 20 mm where the τ_{sN} is 20 which corresponds to a velocity of 2 m/s using Eqs. 1 and 2.

Signals with a strong correlation have a ρ_{xy} close to unity while signals with a weak correlation have lower values of ρ_{xy} . Motevalli [8] reported that $\rho_{xy} > 0.5$ is needed for an accurate velocity measurement. This makes intuitive sense because ρ_{xy} above 0.5 implies greater confidence in the statistical similarity of the signals where as if ρ_{xy} is below 0.5 then it is more likely that the two signals are unrelated. Further discussion on the velocity, temperature measurement capabilities of CCV, and the practical considerations for the cross correlation technique are discussed elsewhere [9, 10], [11].

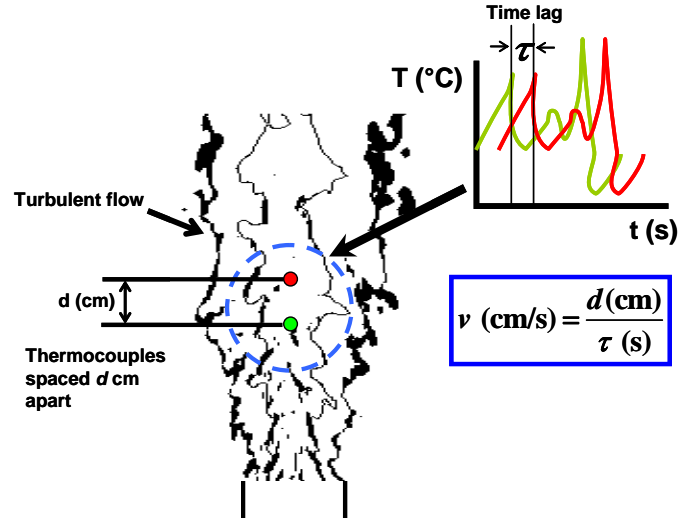

Figure 1: Example of measuring the velocity of a turbulent jet with a CCV Probe. Two thermocouples placed d (cm) apart.

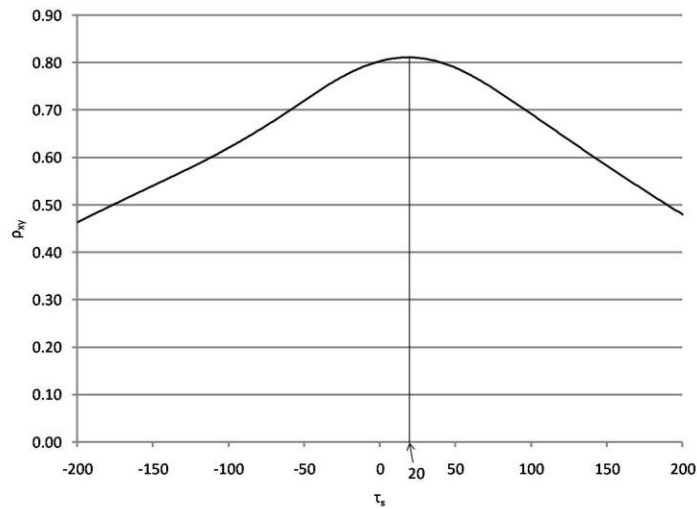

Figure 2: Example of ρ_{xy} versus τ_s for an experiment with a thermocouple separation distance of 20 mm and a sampling rate of 2 kHz.

The measurement of the characteristic turbulent length scale is affected by two main factors, the sampling rate and the sampling period. Using an insufficient sampling frequency will result in the ρ_{xy} being too low and shortening the width measurement. To find the required sampling rate the asymptotic value of ρ_{xy} versus f needs to be found. This is discussed below. A similar type of study needs to be done for the sampling period, having too small of a sampling period will result in a lowering of ρ_{xy} at all separation distances also causing the width prediction to be low.

The total sampling period t_T can be found using,

$$t_T = \frac{T}{f}, \quad (5)$$

where f is the sampling frequency, and T is the total number of samples. To measure an accurate flow profile the sampling period should be long enough to identify the lag in the signal but short enough to show changes in the flow velocity as they occur. To detect as many flow velocity fluctuations as possible the shortest viable sampling period should be used. This minimum total required sampling time is dependent on both the flow condition (turbulent eddy size and the magnitude of thermal gradients) and the quality of data acquisition.

Sampling frequency affects the CCV technique because if data is not recorded fast enough the temperature changes in the turbulent eddies will not be represented correctly by the temperature profile of each thermocouple. Due to the thermal inertia of the probe the maximum viable sampling frequency is proportional to the time constant of the thermocouple. Sampling too fast will simply result in larger data sets which will take longer to analyse with no increase in accuracy. Since the velocity measurement is dependent on the phase, and not the amplitude of the signal, the full response of the thermocouple to the thermal changes in the flow is not needed, therefore the maximum viable sampling frequency is higher than predicted by the thermocouple response time.

To find the width of a flow the maximum viable separation distance for the CCV probe must be found. In the case of a circular free jet the characteristic turbulent length scale is equal to the width of the jet [12]. Therefore the maximum separation distance at which the signals from two thermocouples can be cross correlated with a $\rho_{xy} = 0.5$ should be equal to the width of the flow being analyzed. This conclusion is supported by published findings which report that a turbulent structure can be expected to survive as a recognizable entity through a distance comparable to its own length scale [13].

The width of a circular free jet can be calculated using [14],

$$\frac{2\delta}{d_i} = \left[1 + 24C \frac{x}{d_i} \right], \quad (6)$$

where δ is the jet radius, d_i is the nozzle diameter, x is the height above the nozzle, and C is an empirical constant equal to 0.0128.

3. Experimental Setup:

Axi-symmetric Jet:

Figure 3 shows a diagram of the axi-symmetric jet used to create a uniform and repeatable flow at varying Reynolds Numbers. An electric fan pushed air over electric heaters to generate a constant heated flow. The large scale turbulence structures were generated by viscous shear stress as the jet (nozzle diameter = 5 cm) expands into a clear Plexiglas cage, with dimensions of 46 x 46 x 122 cm. Two E type thermocouples, with wire sizes of 8×10^{-5} m (0.003 inches) were used to make the temperature measurements. E type thermocouples were used because they have a large mV output $61 \mu\text{V}/^\circ\text{C}$ at 25°C compared to other commercially available thermocouples such as K type which has a mV output of $40 \text{ mV}/^\circ\text{C}$ at 25°C [15].

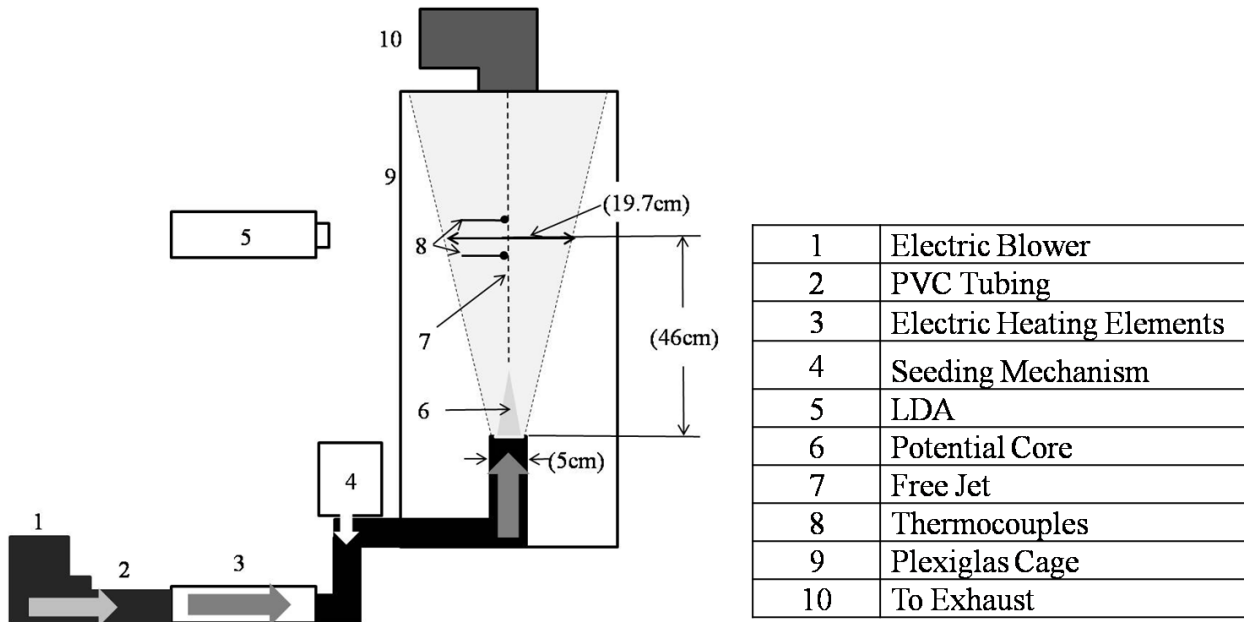

Figure 3: Axi-symmetric jet experimental setup

To confirm that the thermocouples had similar response times the probes were reversed in a constant flow and comparable results were obtained. The separation distance between thermocouples could be varied with accuracy up to 0.01 mm in the flow while keeping the measurement volume at the same height above the jet nozzle. In the vertical plane the thermocouples were aligned using a laser-based alignment system which decreased the error due to misalignment. Thermocouple measurements were recorded by a NI DAQ data acquisition. An intelligent Laser Applications (ILA) 75 mW fixed optical path length fp50-shift LDA system was used as the reference velocity measurement.

Natural Gas burner:

A natural gas burner was built to test the tippie CCV probe's ability to work in a real fire scenario. The burner was built with a 1.22 m by 1.22 m square drywall top with a sand burner in the middle. This tabletop design kept the air entrainment horizontal at the fire's base. The diameter of the burner was adjusted by attaching a steel plate with a hole equal to the desired burner size. Fires having base diameters of 10 cm, 15 cm, and 20 cm and heat release rates between 6.2 kW and 23.7 kW were tested. The heat release rate was determined by adjusting the flow of natural gas to the burner. Measurements were taken at 4 heights above the plume (0.65m, 0.98m, 1.22m, 1.54m). A triple thermocouple probe as shown in figure 4 was built to measure temperature, velocity and plume width simultaneously. The triple CCV probe had separation distances of 4 cm, and 8 cm providing 3 total separation distances (4, 8, and 12cm) with which to calculate the ρ_{xy} decay. The same E type thermocouples used in the Axi-symmetric jet were used here as-well. The thermocouples were aligned in the vertical direction using a plumb bob before each test. To compare with the measurement of CCV probe the plume width was measured using a horizontal thermocouple tree of eight E type thermocouples as shown in figure 4. To find the point of 85% decay in the temperature profile these eight measurements were fitted to a fifth order polynomial which was solved for the desired loss. Due to the low temperatures at the

heights above the plume tested radiation loss incurred a maximum of 0.8% error in the calculation of the width of the plume and was not included.

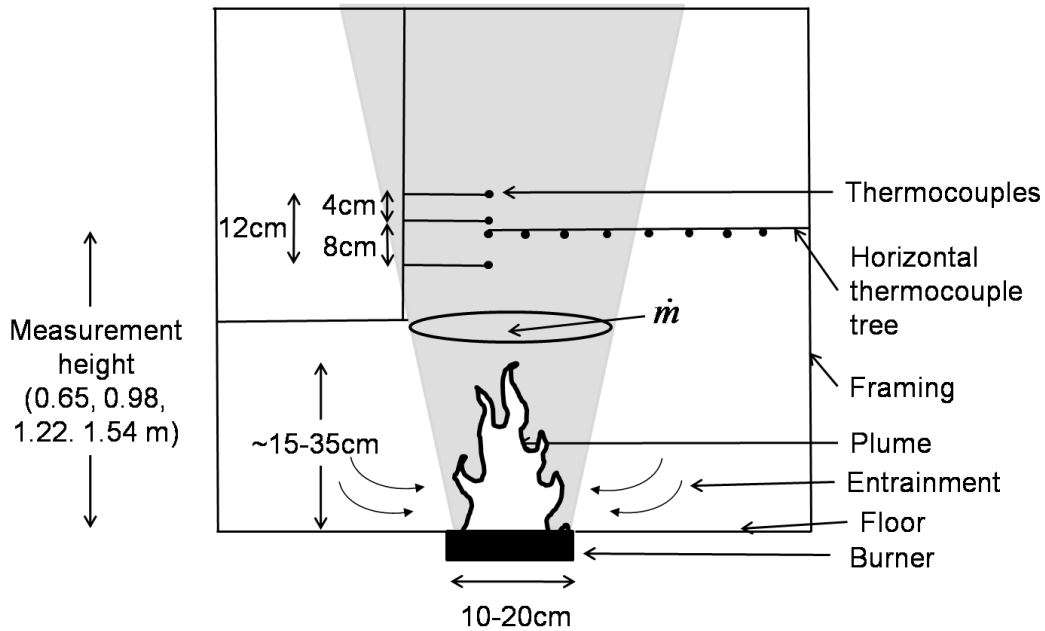

Figure 4: Diagram of triple CCV probe, horizontal thermocouple tree, and burner, burner diameters ranged from 10cm to 20cm.

4. Results and Analysis:

Axi-symmetric Jet:

Figure 5 shows a plot of the correlation coefficient ρ_{xy} versus d (10 mm to 120 mm) from a measurement taken in the axi-symmetric jet. This figure shows a linear decay of ρ_{xy} as the thermocouples become farther apart. Linear extrapolation shows that ρ_{xy} decays to 0.5 at a separation distance of 197mm. Using equation 6 the width of the jet at the measurement location was calculated as 191 mm. To further analyze the use of the decay in ρ_{xy} to predict the width of a flow CCV measurements with varying separation distances were taken in the centerline of the jet and velocity measurements were taken with the LDA along the radius of the jet at different heights above the nozzle. The edge of the jet was defined as when the velocity decayed by 85% of its maximum value. Figure 6 shows that the decay in the ρ_{xy} predicts the jet width within -6.5% of the width measured by the LDA. Because Kanuri's correlation predicts 100% of the jet width, it was adjusted to 85% to match the LDA data. The CCV data presented lies within -13.5% of the adjusted Kanuri's correlation prediction. All CCV width measurements were below the LDA measurements and Kanuri's correlation predictions. This is to be expected because any error in the CCV measurement will cause the ρ_{xy} value to prematurely decay producing a smaller width to be calculated.

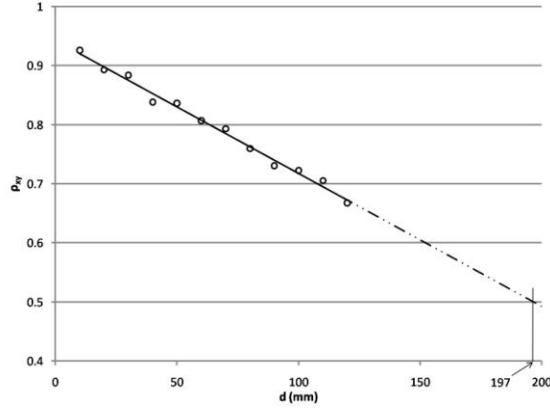

Figure 5: Nondimensional cross correlation coefficient ρ_{xy} versus thermocouple separation distance d , sampling rates 2 kHz, t_T of 15 s, $Re = 4200$. This figure shows the linear decay of ρ_{xy} with increasing separation distance.

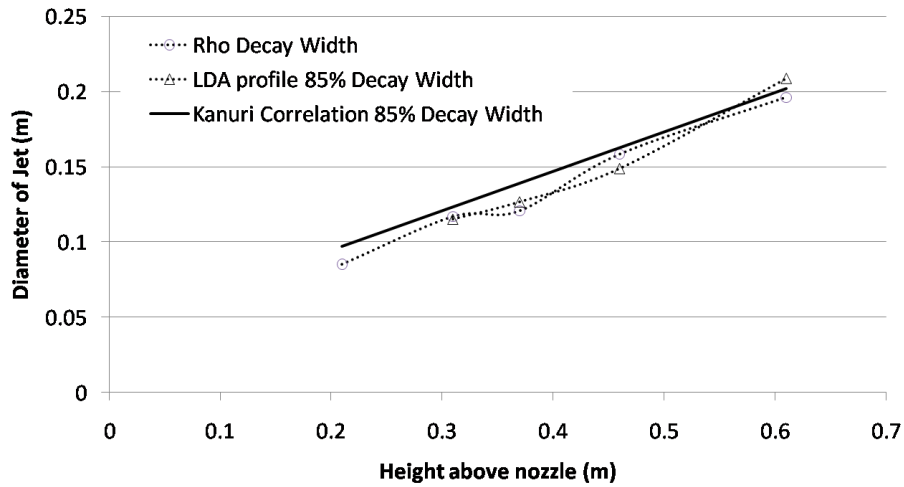

Figure 6: Diameter of turbulent free jet versus height above nozzle

To analyze the dependence of CCV on the sampling frequency experiments were performed at a constant flow varying the sampling frequency between 200 Hz and 10 kHz. Figure 7 shows the relationship between ρ_{xy} and f . After 2 kHz, ρ_{xy} reaches an asymptotic value where increasing the sampling frequency produces little change in the correlation of the signals. This type of result is likely to be flow structure and temperature dependent; flows with large thermal gradients and turbulent structures are expected to have higher ρ_{xy} values using slower sampling rates. Similar results were found in all of the Reynolds numbers tested in this study, a $f = 2$ kHz represents an optimum sampling rate for the range of flow conditions tested.

To determine the sampling period dependence of the CCV, calculations were done using a range of total sampling periods, t_T . In figure 8 the relationship between ρ_{xy} and the total sampling time is shown. For the flow conditions presented a total sampling time of 5 seconds is required ($Re = 4200$, $f = 2$ kHz) to reach an asymptotic value usable for the decay in ρ_{xy} calculation.

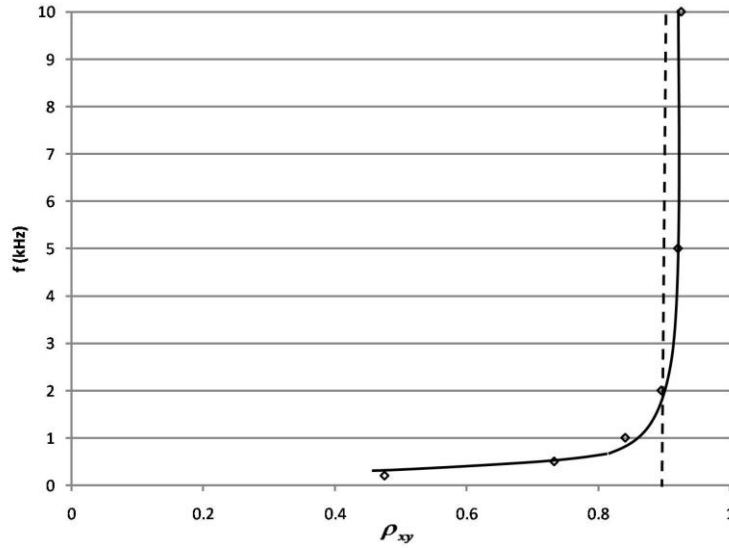

Figure 7: Sampling frequency f versus nondimensional cross correlation coefficient ρ_{xy} for a thermocouple separation distance of 10 mm using a 15-second sampling time. The nondimensional cross correlation coefficient reaches an near asymptotic value at 2 kHz.

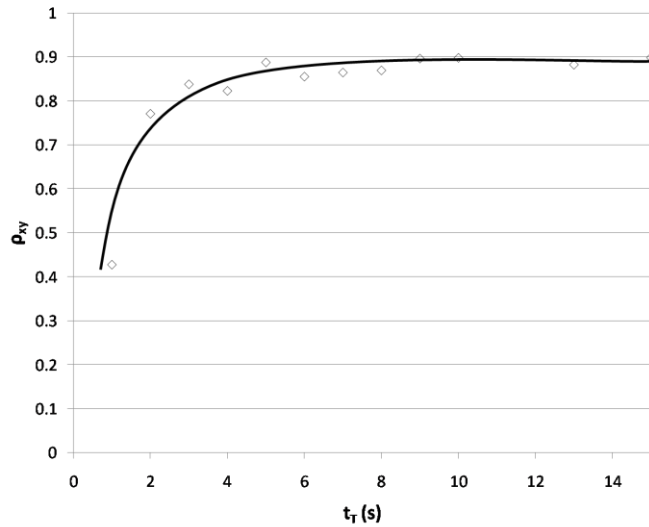

Figure 8: ρ_{xy} versus t_T , $Re=4200$ and $f = 2$ kHz. ρ_{xy} reaches an asymptotic value with a sampling time of 6 seconds.

Natural Gas Burner:

Using the triple CCV probe simultaneous measurements of temperature, velocity, and plume width were made near the centre of a fire plume above the natural gas burner with a sampling frequency of 10 kHz and a sampling period of 10 s. The velocity of the plume was not measured directly but the CCV measurements were within the range of velocities predicted by McCaffrey's [16] and Heskestad's [17] correlations. Figure 9 shows the width of an 85% decay in the temperature profile versus the width predicted by the decay in ρ_{xy} for three different burner diameters and six different heat release rates. Width measured using CCV were within $\pm 25\%$ of the thermocouple width measurements. On average the CCV width measurements were 8.4% smaller than the thermocouple width measurements. These differences could be due to a number

of factors including: uneven deposition of soot on the thermocouple beads causing the thermocouples to have differences in their time constants, an offset in the alignment of the thermocouples along the centerline of the plume, varying plume angles due to ambient air flow in the lab, or having three thermocouples inline making a single measurement which adds more disturbances into the flow as opposed to the normal dual CCV probe. However the error in these measurements seem to be reasonable for most measurements made in a turbulent fire environment. Experimental Observations were also compared with empirical plume width correlations reported in literature [17]. Heskestad's plume width correlation over predicts experimental results by 25%. This could be due to the small fire sizes (6.2-23.7 kW) used in this study.

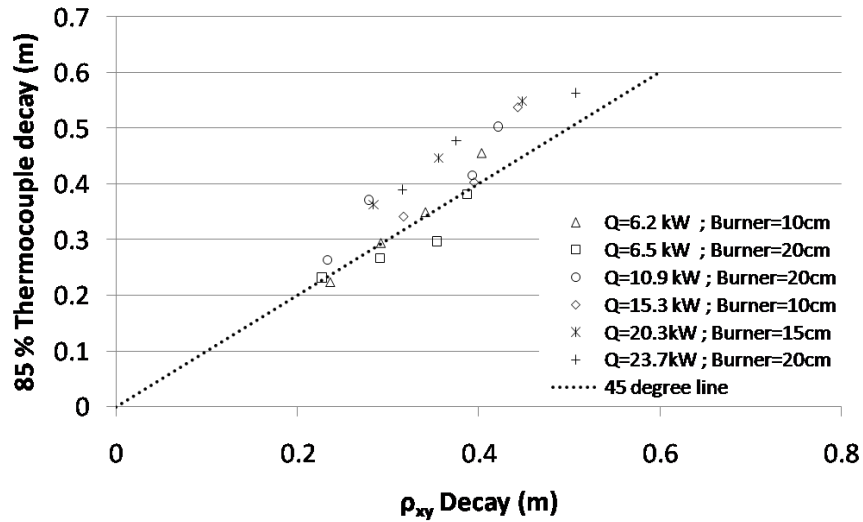

Figure 9: Plume width measured using a thermocouple tree versus plume width predicted by the decay in the CCV nondimensional cross correlation coefficient. $f = 10 \text{ kHz}$, $t_T = 10 \text{ s}$.

The mass flux \dot{m} of a fire plume can be approximated assuming a top hat flow profile using,

$$\dot{m} = \rho u \frac{\pi}{4} D^2, \quad (7)$$

where ρ is the average air density, u is the flow velocity, and D is the width of the plume. The density of the flow can be estimated using the temperature measurement and the ideal gas law. Knowing the mass flux from a fire plume is important for calculating how fast smoke detectors will activate, how quickly the upper layer will grow which is needed for evacuation calculations and calculating the ventilation requirements in a given space. The triple CCV probe is unique because it allows the user to measure all three of the quantities needed to use this equation simultaneously.

The measurement of the decay in ρ_{xy} can likely be used to estimate the ceiling jet caused by a compartment fire. Ceiling jet refers to the gas flow in a layer beneath the ceiling surface driven by the buoyancy of hot combustion products from a fire plume. Characterization of ceiling jet thickness is important in the analysis of sprinkler activation, flashover calculations, and tenability/egress analysis in compartment fires that occur in, for example, structural and

tunnel fires. Figures 10a and 10b show diagrams of a typical ceiling jet generated by a fire at the back of a room and the expansion of a circular free jet respectively.

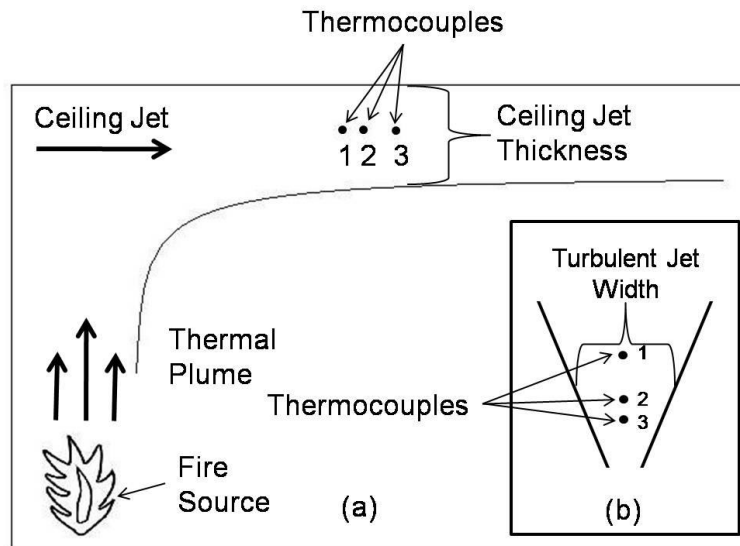

Figure 10: Application of CCV to measure characteristic turbulent length scales. (a) Typical ceiling jet found in a compartment fire. (b) Axi-symmetric free jet

5. Conclusions

The triple CCV probe can measure the temperature, velocity, and characteristic turbulent length scale of a medium to high temperature turbulent flow which allows the direct calculation of a fire plumes mass flux. The CCV's width measurement is most effected by 2 main factors, sampling frequency and sampling time. For different types of flow conditions in which these measurements are done an analysis to find the asymptotic value for these two parameters is required. For the flows tested here, the minimum required sampling time was found to be 5 seconds and the optimum sampling frequency was found to be 2 kHz.

In the future this technique could be used to measure the ceiling jet thickness in compartment fires. Future work is needed to characterize the angular dependence of this measurement, how far away from the centre of the plume the thermocouple sensor can be placed before an accurate measurement of the plume width is no longer possible, and how close to the characteristic turbulent length scale the thermocouple separation distance can be and still make a valid measurement. These parameters are important for using the triple CCV probe to measure the ceiling jet thickness.

Acknowledgments

The help of laboratory manager Randy Harris is acknowledged. This work was partially funded by the Society of Fire Protection Engineering (SFPE) Education and Scientific Foundation Grant. The research is currently funded through the National Science Foundation (NSF) Graduate Research Fellowship Program (GRFP).

References

1. Tieszen, S.R., *On the Fluid Mechanics of Fires*. Annual Rev. Fluid Mech., 2001. **33**: p. 67-92.
2. Marvasti, M.A. and W.C. Strahle, *Fractal interpolation methods in spatial cross-correlation velocimetry*. Experiments in Fluids, 1994. **18**: p. 129-130.
3. Morgan, M.G. and K.L. Bowles, *Cross-Correlation and Cross-Spectral Methods for Drift Velocity Measurements*. Science, 1968. **161**(3846): p. 1139-1142.
4. Taylor, G.I., *The Spectrum of Turbulence*. Proc Roy. Soc. A, 1938. **164**: p. 476-490.
5. Cox, G., *Some Measurements of Fire Turbulence*. Fire and Mat., 1976. **1**: p. 116-122.
6. Cox, G. and R. Chitty, *Study of the Deterministic Properties of Unbounded Fire Plumes*. Comb. and Flame, 1980. **39**: p. 191-209.
7. Cox, G., *Gas Velocity Measurement in Fires by the Cross Correlation of random Thermal Fluctuations*, in *Fire Research Note 1032*. 1975: Borehamwood.
8. Motevalli, V., *A Study of the Characteristics of Small-Scale Unconfined Fire Induced Ceiling Jets*, in *ME*. 1989, University of Maryland, College Park.
9. Cox, G., *Gas Velocity Measurements in Fires by the Cross-Correlation of Random Thermal Fluctuations- A Comparison with Conventional Techniques*. Comb. and Flame, 1977. **28**: p. 155-163.
10. Motevalli, V., C.H. Marks, and B.J. McCaffrey, *Cross-correlation velocimetry for measurement of velocity and temperature profiles in low-speed, turbulent, nonisothermal flows*. Journal of Heat Transfer (Transactions of the ASME), 1992.
11. Wills, J.A.B., *On Convection Velocities in turbulent Shear Flows*. Journal of Fluid Mechanics, 1964. **20**(3): p. 417-432.
12. Turns, S.R., *An Introduction to Combustion: Concepts and Applications*. 2000, New York: McGraw Hill.
13. Coats, C.M., *Coherent Structures in Combustion*. Prog. Energy Combustion Science, 1996. **22**: p. 427-509.
14. Kanury, A.M., *An Introduction to Combustion Phenomena*. 1977: Gordon & Breach Science Publishers, Inc.
15. Technologies, A., *Application Notes - Practical Temperature Measurements*. 2008: USA. p. 11.
16. Drysdale, D., *An Introduction to Fire Dynamics*. 1999: John Wiley & Sons.
17. Karlsson, B. and J.G. Quintiere, *Enclosure Fire Dynamics*. 2000: CRC Press.